

PETRA

— Innovative
shapes and precious
materials for a new
bathroom idea.

ARTESI



PETRA

Design Enrico Cesana



ARTESI

Petra System

Innovative shapes
and precious materials
for a new bathroom idea.

La nuova Collezione Petra by Artesi è un sistema evoluto, capace di svilupparsi nello spazio attraverso la sua vasta modularità e sfaccettata matericità, adattandosi ad ogni tipo di esigenza funzionale ed estetica.

Petra veste il tuo bagno con rigore, eleganza e naturalezza.

The new Petra Collection by Artesi is an advanced system, able to extend itself in the space thanks to its vast modularity and multi-faceted matericity and to adapt to every type of functional and aesthetic demand.

Petra dresses your bathroom with rigour, elegance and simplicity.

Die neue Petra Kollektion von Artesi ist ein fortgeschrittenes System, das sich dank seiner reichen Modularität und materischen Texturen im Raum erweitert und an jede Art von funktionalen und ästhetischen Anforderungen anpassen kann.

Petra kleidet Ihr Badezimmer mit Formstrenge, Eleganz und Einfachheit.

La nouvelle collection Petra d'Artesi est un système avancé, capable de se développer dans l'espace grâce à sa grande modularité et à sa polyvalence matérielle, en s'adaptant à tous les types de demandes fonctionnelles et esthétiques.

Petra habille votre salle de bain avec rigueur, élégance et simplicité.







1 / **Petra**

Fango opaco / Cassetto Rovere Palude / Top Street
 Fango matt / Drawer oak Palude / Vanity Top Street
 Fango matt / Schublade Eiche Palude / Abdeckplatte Street
 Fango mat / Tiroir chêne Palude / Plan Street

Comp. PT 40 L.120 X P.45,5 cm









2 / **Petra**

Bianco Opaco / Top e fianchi Reef Grigio
White matt / Vanity top and sides Reef Grigio
Weiß matt / Waschtischplatte und Seiten Reef Grigio
Blanc mat / Plan vasque et côtés Reef Grigio

Comp. PT 41 L.144 X P.45,5 cm







3 / Petra

Burro Opaco / Roccia Opaco / Top Rail
 Burro matt / Roccia matt / Vanity top Rail
 Burro matt / Roccia matt / Waschtischplatte Rail
 Burro mat / Roccia mat / Plan vasque Rail

Comp. PT 42 L.170 X P.45,5 cm



Una linea morbida che caratterizza il tuo bagno.

Una linea continua, un segno morbido che sagoma i frontali della Collezione Petra conferendole pulizia formale e praticità. La particolare sagomatura dell'anta crea una "gola" che permette una facile apertura mantenendo invariata l'estetica lineare.

A soft line that characterizes your bathroom. A continuous line, a soft sign that defines the fronts of the Petra Collection, lending formal elegance and practicality. The particular shape of the door has a "groove" handle that allows an easy opening, leaving the linear aesthetics unchanged.

Eine weiche Linie, die Ihr Badezimmer kennzeichnet. Eine durchgehende Linie und ein weiches Zeichen kennzeichnet die Fronten der Petra Kollektion und gleichzeitig eine formale Eleganz und Zweckmäßigkeit verleiht. Die besondere Form der Tür drückt sich durch eine Griffmulde aus, die eine einfache Öffnung erlaubt; die lineare Ästhetik bleibt unverändert.

Une ligne douce qui caractérise votre salle de bain. Une ligne continue, un signe doux qui définit les façades de la Collection Petra, donnant élégance et praticité. La forme particulière de la poignée "à gorge" permet une ouverture facile, laissant l'esthétique linéaire inchangée.







4 / **Petra**

Quarzo Opaco / Top Street in Cristalplant / Fianchi bianco opaco
Quarzo matt / Street vanity top in Cristalplant / White matt sides
Quarzo matt / Waschtischplatte Street aus Cristalplant / Weiß matt Seiten
Quarzo mat / Plan vasque Street en Cristalplant / Côtés blanc mat
Comp. PT 43 L.190 X P.45,5 cm





5 / **Petra**

- Paulownia Grigio / Top Roccia Opaco / Lavabo Ombra Creta
 - Paulownia Grigio / Top Roccia matt / Vessel basin Ombra Creta
 - Paulownia Grigio / Waschtischplatte Roccia matt / Aufsatzbecken Ombra Creta
 - Grigio paulownia / Plan Roccia mat / Lavabo Ombra Creta
- Comp. PT 44 L.170 X P.45,5 cm**





6 / **Petra**

Grigio Fumo Opaco / Top e fianchi Gres Nero Greco
Grigio Fumo matt / Vanity top and sides Gres Nero Greco
Grigio Fumo matt / Waschtischplatte und Seiten Gres Nero Greco
Grigio Fumo mat / Plan vasque et côtés Gres Nero Greco

Comp. PT 45 L.122,4 X P.45,5 cm









7 / Petra

Grigio Londra Opaco / Top e fianchi Reef Grigio
Grigio Londra matt / Vanity top and sides Reef Grigio
Grigio Londra matt / Waschtischplatte und Seiten Reef Grigio
Grigio Londra mat / Plan vasque et côtés Reef Grigio

Comp. PT 46 L.243,6 X P.50 cm









8 / Petra

Rovere Scandinavia / Nebbia Opaco / Top Gres Pietra d'Iseo
 Oak wood Scandinavia / Nebbia matt / Vanity top Gres Pietra d'Iseo
 Eiche Scandinavia / Nebbia matt / Waschtischplatte Gres Pietra d'Iseo
 Chêne Scandinavia / Nebbia Mat / Plan vasque Gres Pietra d'Iseo

Comp. PT 47 L.145 X P. 45,5 cm







9 / Petra

Mattone Opaco / Top Stone Ardesia Piombo
 Mattone matt / Vanity top Stone Ardesia Piombo
 Mattone matt / Waschtischplatte Stone Ardesia Piombo
 Mattone mat / Plan vasque Stone Ardesia Piombo

Comp. PT 48 L.240 X P.50 cm







10 / **Petra**

Bianco Opaco / Top Bianco Opaco / Lavabo Planet-in
 White matt / White matt top / Vessel basin Planet-in
 Weiß matt / Abdeckplatte Weiß matt / Waschbecken Planet-in
 Blanc mat / Plan Blanc mat / Lavabo Planet-in

Comp. PT 49 L.315 X P.50 cm





Qualità ed eleganza nella nuova anta Band.

Band è un segno verticale minimale di grande carattere, che conferisce eleganza e ricercatezza al tuo bagno. La lavorazione del legno sul frontale dell'anta rappresenta la nuova espressione di qualità di Artesi.

The new door Band: Quality and elegance. Band is a minimal vertical sign of great character, which gives elegance and sophistication to your bathroom. The processing technique of the front of the door represents a new expression of quality by Artesi.

Das neue Tür Band: Qualität und Eleganz. Band ist ein minimales vertikales Zeichen von großem Charakter, das Ihrem Badezimmer Eleganz und Geziertheit verleiht. Die Verarbeitungstechnik der Türfront repräsentiert ein neuer Qualitätsausdruck von Artesi.

La nouvelle façade Band: qualité et élégance. La façade Band est un signe vertical minimal de grand caractère, ce qui donne élégance et préciosité à votre salle de bain. La menuiserie de la façade représente une nouvelle expression de qualité par Artesi.



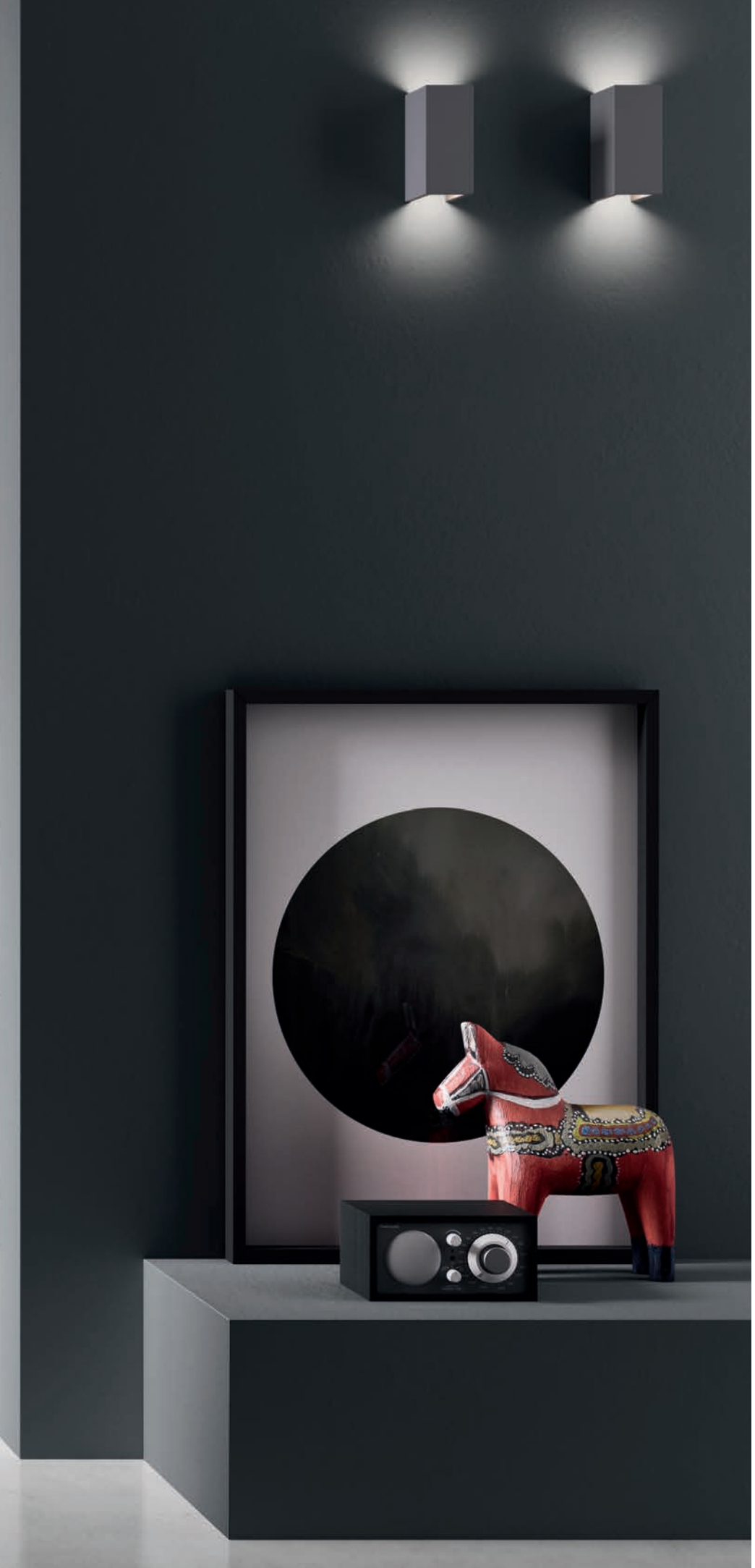



11 / Petra

Rovere Colombia Band / Top e fianchi Gres Azalai Nero
 Oak wood Colombia Band / Vanity top and sides Gres Azalai Nero
 Eiche Colombia Band / Waschtischplatte und Seiten Gres Azalai Nero
 Chêne Colombia Band / Plan vasque et côtés Gres Azalai Nero

Comp. PT 50 L.148 X P.50 cm





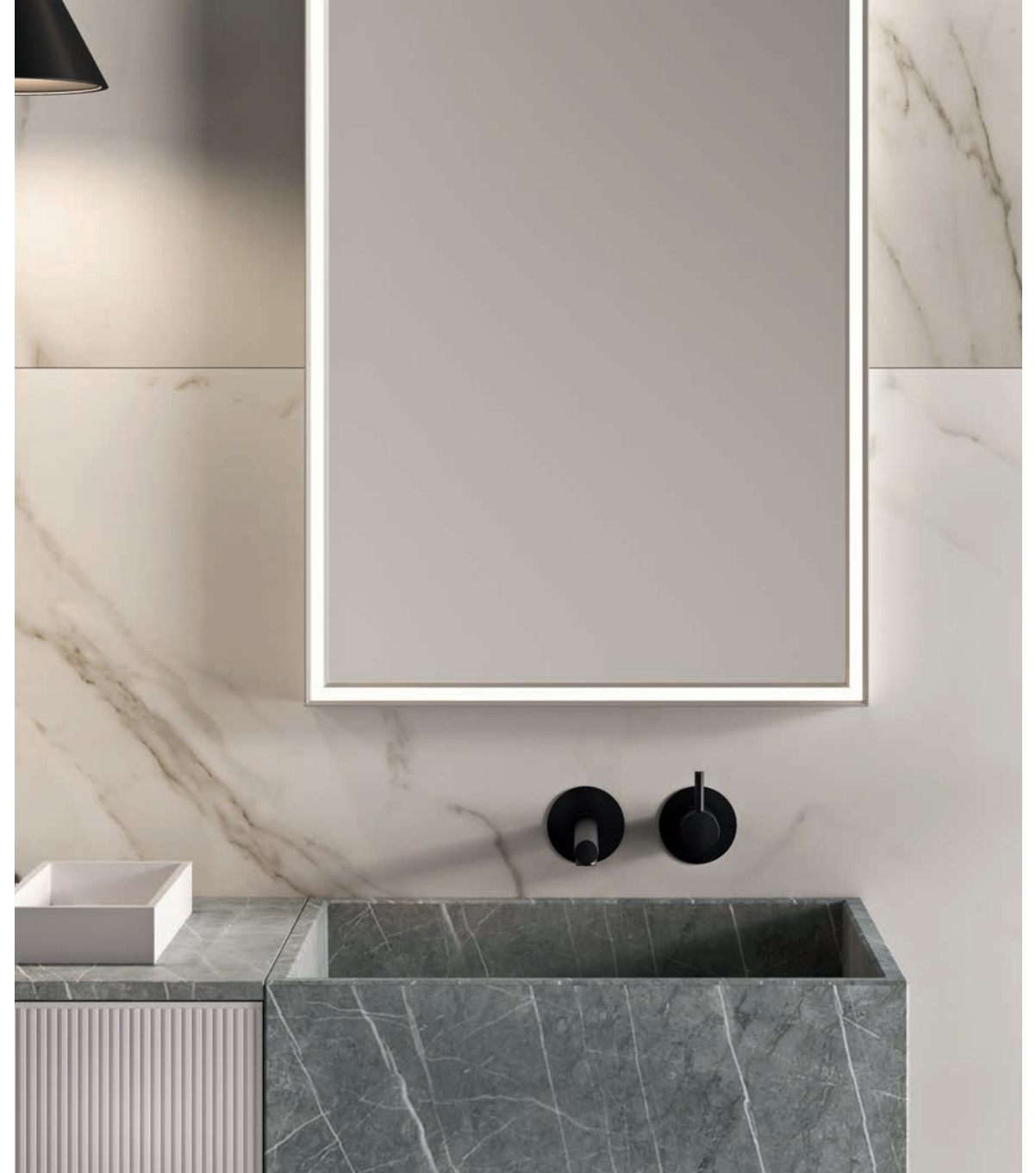

12 / **Petra**

Bianco Opaco Band / Top, fianchi e lavabo Gres Stone Silk
White matt Band / Sides, top and Vessel basin Gres Stone Silk
Weiß matt Band / Waschtischplatte und Seiten Gres Stone Silk
Blanc mat Band / Côtés et plan vasque en Gres Stone Silk

Comp. PT 51 L.146,2 X P.45,5 cm





13 / Petra

Rovere Colombia Band / Top Gres Pietra d'Iseo
 Oak wood Colombia Band / Vanity top Gres Pietra d'Iseo
 Eiche Colombia Band / Waschtischplatte Gres Pietra d'Iseo
 Chêne Colombia Band / Plan vasque Gres Pietra d'Iseo

Comp. PT 52 L.190 X P.50 cm

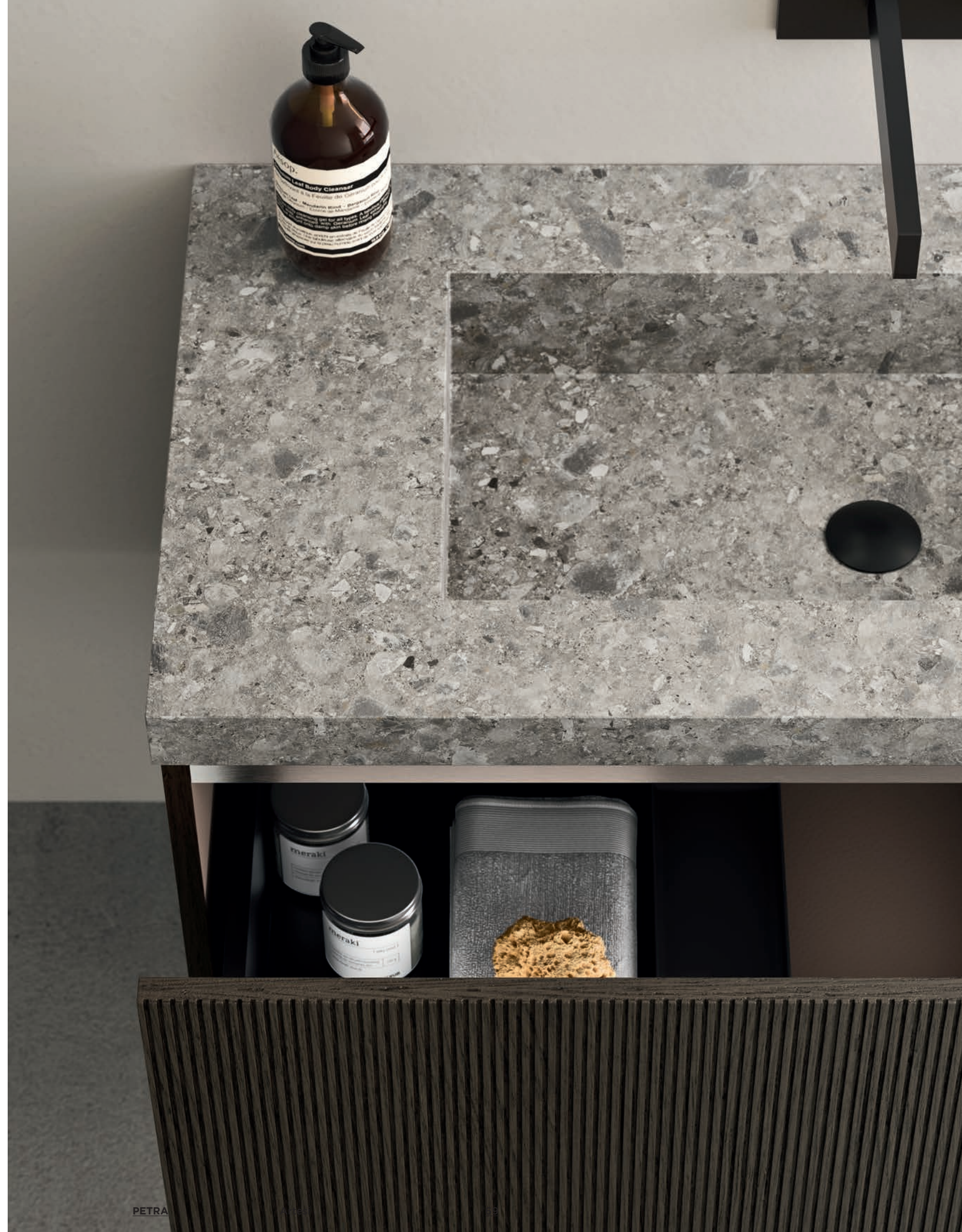







14 / **Petra**

Roccia Opaco / Top e fianchi Rovere Palude / Lavabo Blob
Roccia matt / Vanity top and sides Oak wood Palude / Vessel basin Blob
Roccia matt / Waschtischplatte und Seiten Eiche Palude / Aufsatzbecken Blob
Roccia mat / Plan vasque et côtés en Chêne Palude / Lavabo Blob

Comp. PT 53 L.142,8 X P.50 cm







15 / **Petra**

Lino Opaco / Tortora Opaco / Top Concrete Tortora
 Lino Matt / Tortora matt/ Vanity top Concrete Tortora
 Lino Matt / Tortora matt / Waschtischplatte Concrete Tortora
 Lino Mat / Tortora mat / Plan vasque Concrete Tortora

Comp. PT 54 L.170 X P.50 cm







16 / Petra

Blu Cobalto Opaco / Bianco Opaco / Top Street in Cristalplant

Blu Cobalto matt / White matt / Street vanity top in Cristalplant

Blu Cobalto matt / Weiß matt / Waschtischplatte Street aus Cristalplant

Blu Cobalto mat / Blanc mat / Plan vasque Street en Cristalplant

Comp. PT 55 L.170 X P.45,5 cm





17 / **Petra**

- Noce Miele / Top Street in Cristalplant
- Noce Miele / Street vanity top in Cristalplant
- Noce Miele / Waschtischplatte Street aus Cristalplant
- Noce Miele / Plan vasque Street en Cristalplant

Comp. PT 56 L.170 X P.45,5 cm





18 / **Petra**

Malta Bianco / Top Smart Bianco Opaco
Malta White / Smart Vanity top White Matt
Malta Weiß / Waschtischplatte Smart Weiß matt
Malta Blanc / Plan vasque Smart blanc mat

Comp. PT 57 L.210 X P.50 cm

19/Petra

Composition

Azzurro Polvere Opaco / Top Cover Bianco
Azzurro Polvere Matt / White vanity top Cover
Azzurro Polvere Matt / Waschtischplatte Cover Weiß
Azzurro Polvere Mat / Plan vasque Cover blanc

Comp. PT 58 L.70 X P.50 cm









20 / **Petra**

Malta Bianco / Lavabo Kubik
White Malta / Basin Kubik
Malta Weiß / Waschbecken Kubik
Malta Blanc / Lavabo Kubik

Comp. PT 59 L.190 X P.50 cm





21/Petra

Composition

Bianco Opaco / Lavabo Plano Bianco
White matt / Vanity top Plano
Weiß matt / Waschtischplatte Plano Weiß
Blanc mat / Plan vasque Plano

Comp. PT 60 L.165 X P.50 cm

Componi il tuo Petra

Compose your Petra / Stellen Sie Ihre Petra zusammen / Comment composer votre salle de bain Petra

1 Definisci la struttura

Define the structure / Definieren Sie den Korpus / Définir le caisson

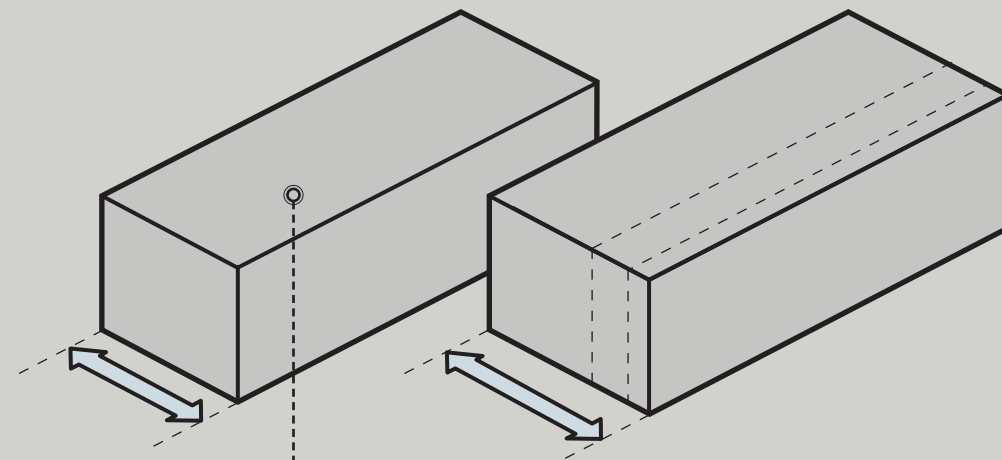

Profondità / Depth / Tiefe / Profondeur
35 cm - 45,5 cm - 50 cm

2 Crea volumi pieni e vuoti

Create full and empty volumes / Kombinieren Sie volle und leere Volumen / Créer des volumes pleins et vides

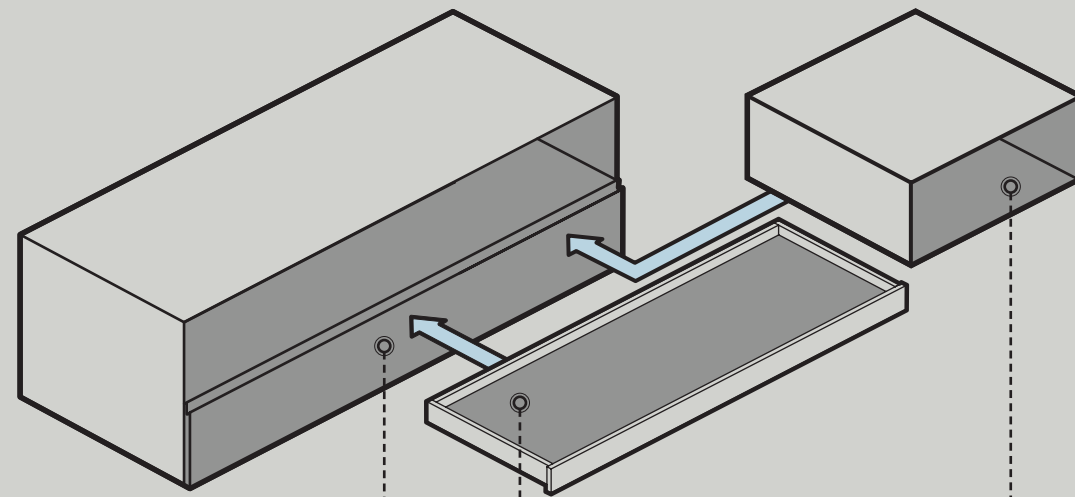

Cassetto con gola
/ Drawer with groove handle
/ Schublade mit Griffmulde
/ Tiroir avec poignée à gorge

Cassetto a giorno
/ Little extractable drawer
/ Kleine ausziehbare Schublade
/ Petit tiroir extractible

Vani a giorno
/ Open cabinets
/ Offene Elemente
/ Meubles bas ouvertes

3 Scegli la tipologia di lavabo

Choose the vanity top / Wählen Sie die Waschtischplatte / Choisir le plan

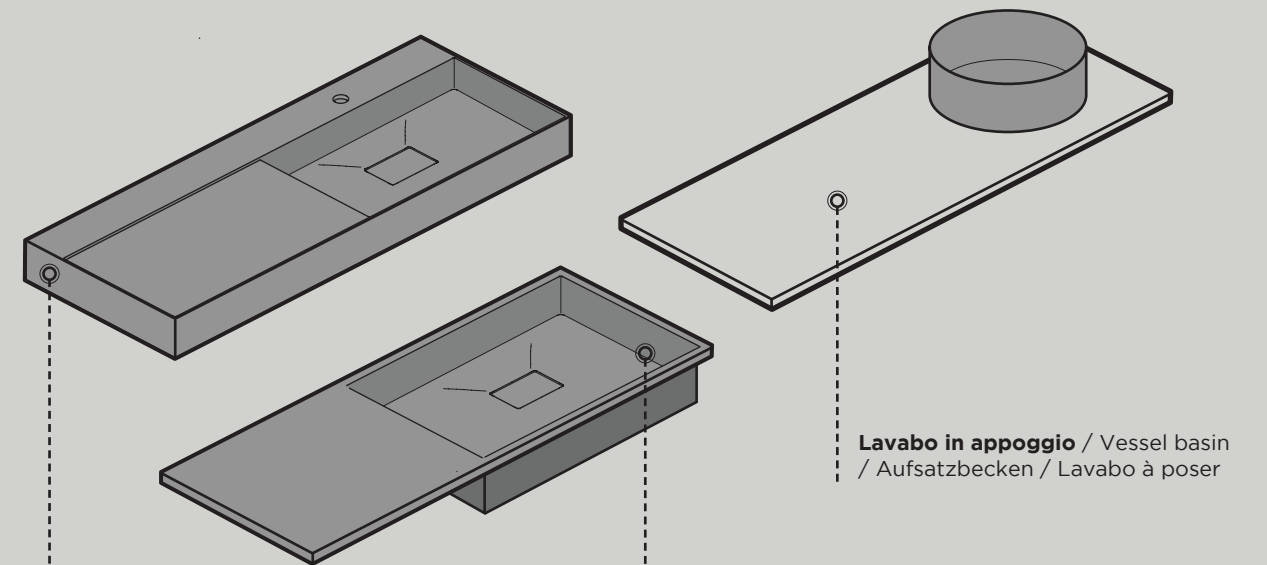

Lavabo Street / Vanity top Street
/ Waschtischplatte Street / Plan vasque Street

Lavabo integrato
/ Vanity top integrated
/ Abdeckplatten mit integriertem Waschbecken
/ Plan avec vasque moulée

Lavabo in appoggio / Vessel basin
/ Aufsatzbecken / Lavabo à poser

4 Scegli se aggiungere le spalle terminali

Choose whether to add the sides / Wählen Sie aus, ob die Seiten hinzugefügt werden sollen / Choisir si vous souhaitez ajouter les côtés

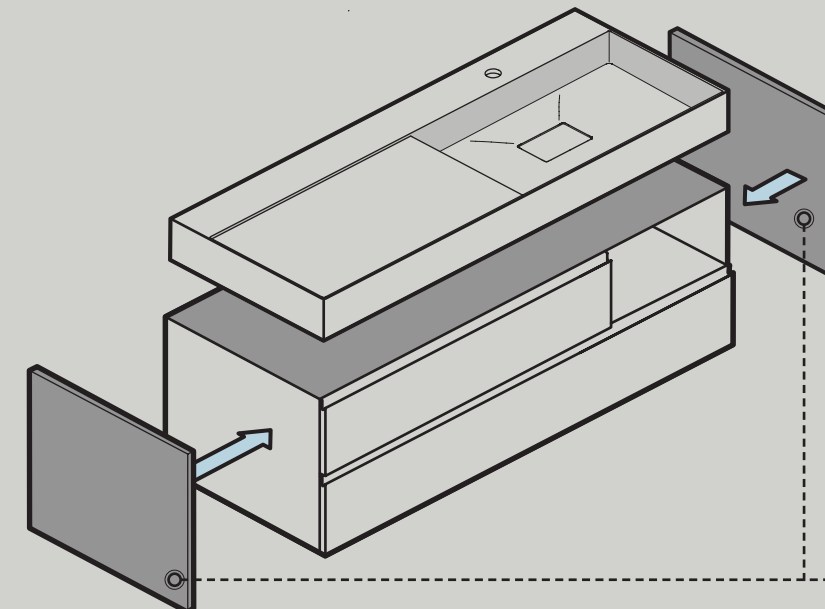

Spalle terminali
/ Sides
/ Seiten
/ Côtés

Composizioni

Compositions / Compositions / Kompositionen

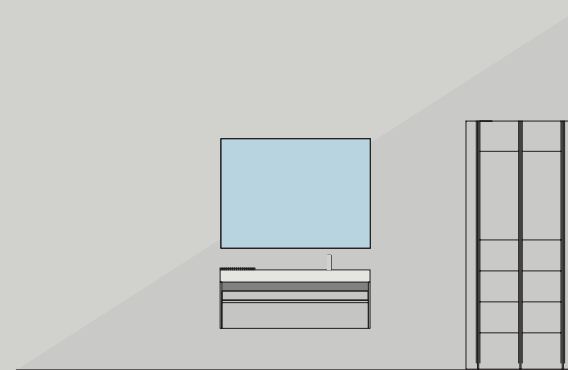

1 / Petra
Comp. PT 40 L.120 X P.45,5 cm

04

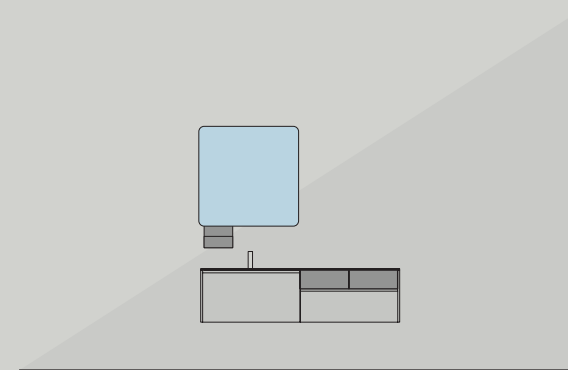

2 / Petra
Comp. PT 41 L.144 X P.45,5 cm

10

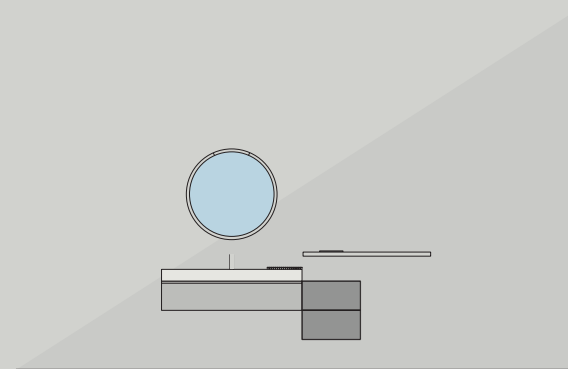

3 / Petra
Comp. PT 42 L.170 X P.45,5 cm

16

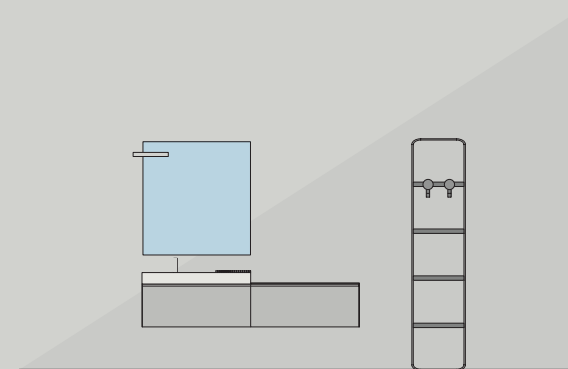

4 / Petra
Comp. PT 43 L.190 X P.45,5 cm

22

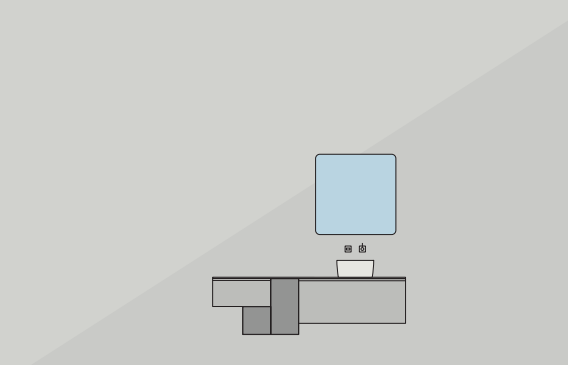

5 / Petra
Comp. PT 44 L.170 X P.45,5 cm

26

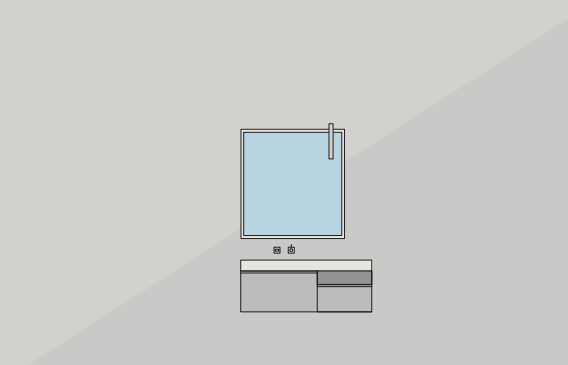

6 / Petra
Comp. PT 45 L.122,4 X P.45,5 cm

30

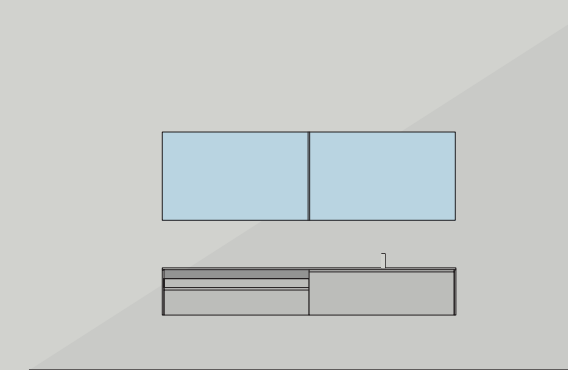

7 / Petra
Comp. PT 46 L.243,6 X P.50 cm

36

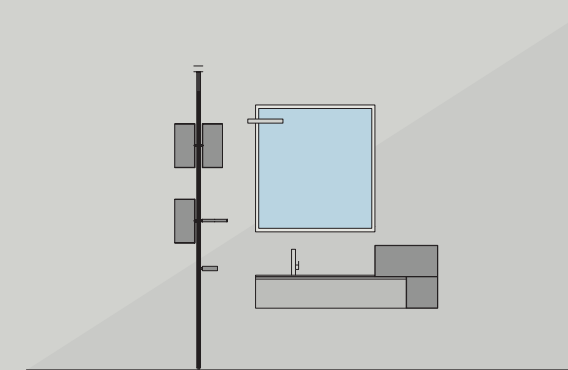

8 / Petra
Comp. PT 47 L.145 X P. 45,5 cm

42

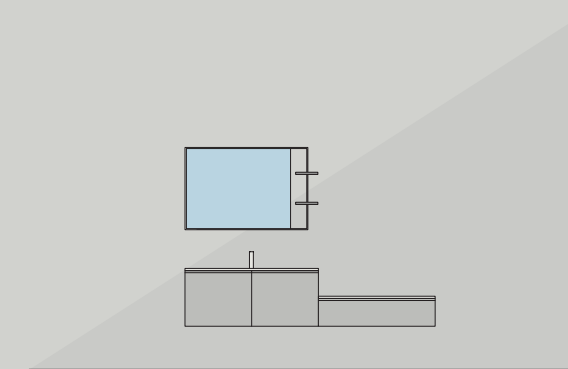

9 / Petra
Comp. PT 48 L.240 X P.50 cm

46

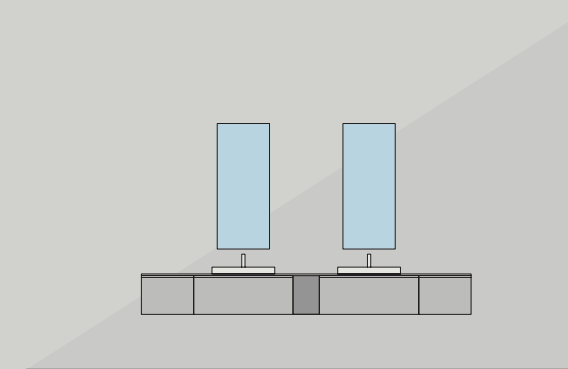

10 / Petra
Comp. PT 49 L.315 X P.50 cm

50

define your space

Define your space / Wählen Sie Ihre Räume / Choisissez vos espaces

define **your** space

Define your space / Wählen Sie Ihre Räume / Choisissez vos espaces

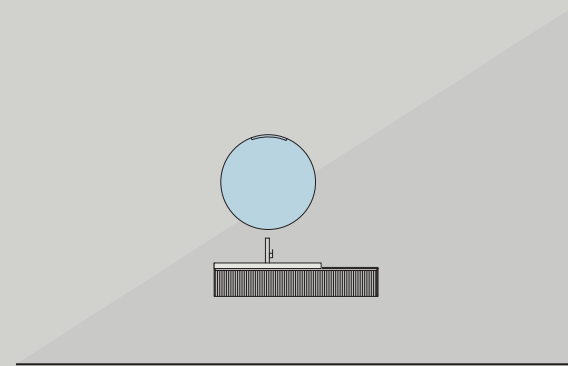

11 / **Petra**
Comp. PT 50 L.148 X P.50 cm

58



12 / **Petra**
Comp. PT 51 L.146,2 X P.45,5 cm

62

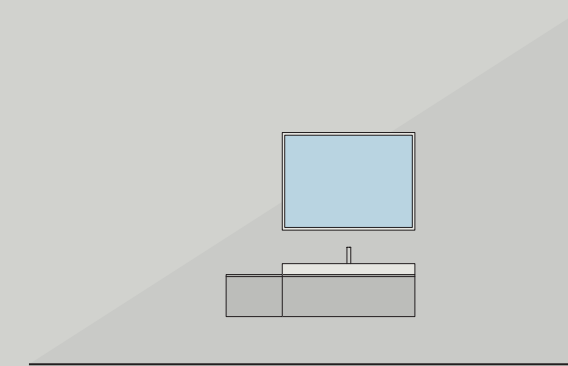

17 / **Petra**
Comp. PT 56 L.170 X P.45,5 cm

86

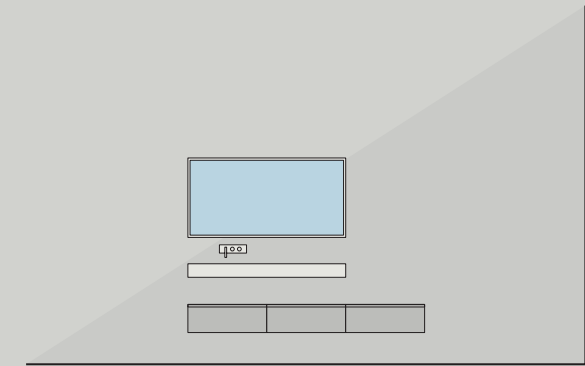

18 / **Petra**
Comp. PT 57 L.210 X P.50 cm

90

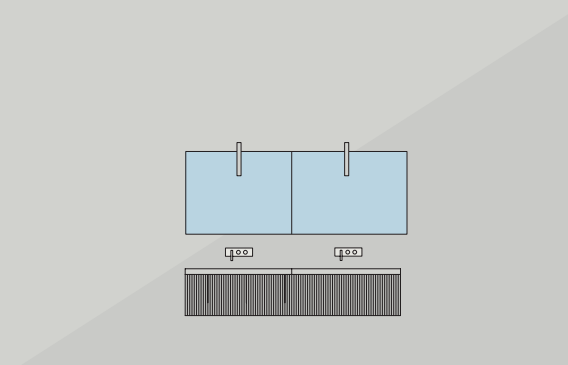

13 / **Petra**
Comp. PT 52 L.190 X P.50 cm

66

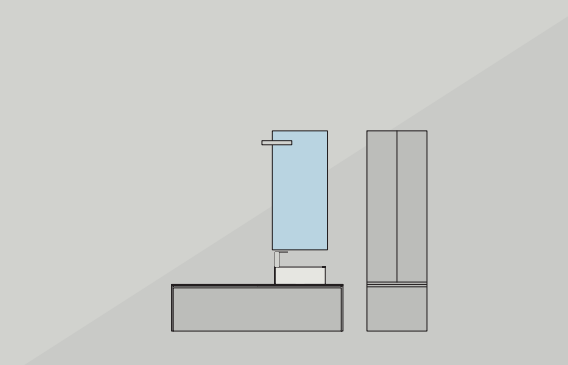

14 / **Petra**
Comp. PT 53 L.142,8 X P.50 cm

72

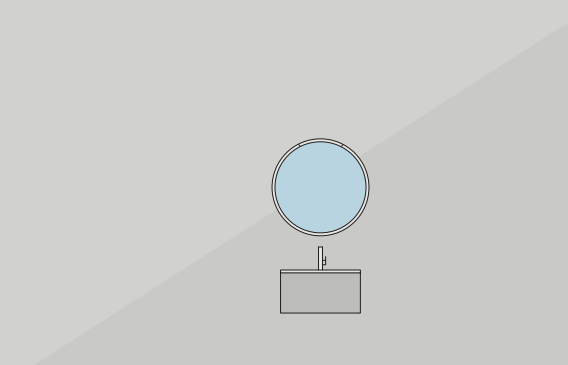

19 / **Petra**
Comp. PT 58 L.70 X P.50 cm

94

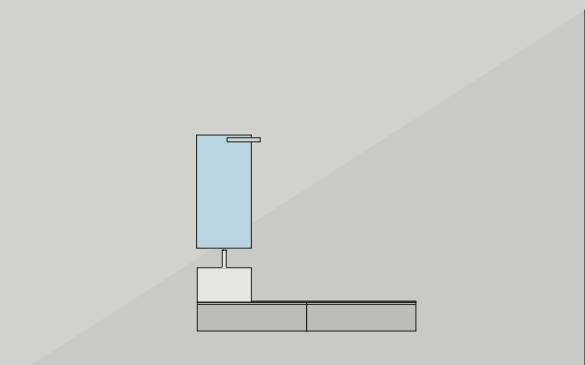

20 / **Petra**
Comp. PT 59 L.190 X P.50 cm

98

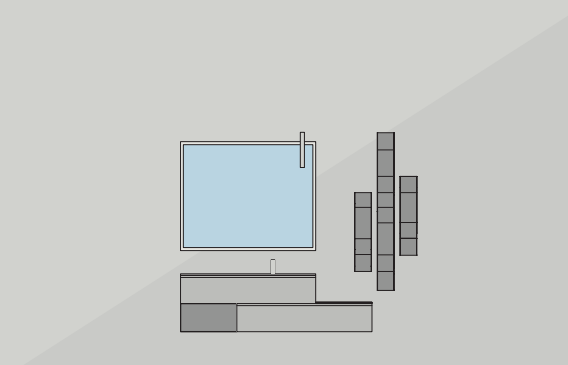

15 / **Petra**
Comp. PT 54 L.170 X P.50 cm

78

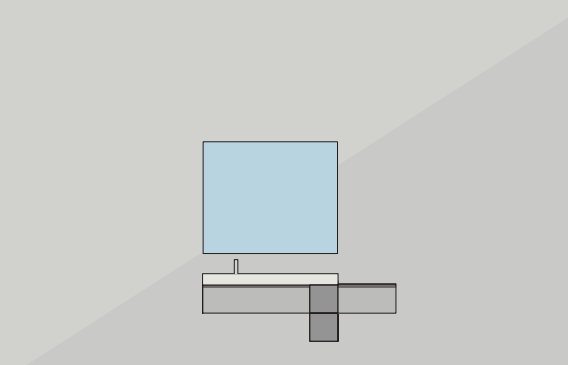

16 / **Petra**
Comp. PT 55 L.170 X P.45,5 cm

82



21 / **Petra**
Comp. PT 60 L.165 X P.50 cm

102

Certificazioni

Certification / Beurkundungen/ Certification



MADE IN ITALY

Sicurezza e durata

Le scocche sono garantite dal marchio Idropan, uno speciale melaminico idrorepellente, resistente all'acqua e all'umidità, che contraddistingue l'anima nascosta dei mobili di qualità. L'azienda inoltre ha aderito al consorzio del pannello ecologico e utilizza cioè solamente pannelli realizzati con materiale riciclato al 100%. Tutti gli elementi sono studiati per vivere il bagno in tutta sicurezza ogni giorno: cerniere brevettate, agganci e finiture testate contro l'azione dell'umidità, ruote adatte per i contenitori, guide sotto-cassetto a scomparsa, accessori elettrici certificati.

Safety and lifespan

Our furniture structures are guaranteed by the Idropan brand, a special melamine-coated panel, which resists to water and dampness and characterizes furniture of quality. Moreover the company makes part of the consortium of the ecological panel, using only 100% recycled panels. All the elements are meant to facilitate the daily use of the bathroom in safety: patented hinges, hooks and finishes tested to resist to dampness, resistant wheels for cabinets, no visible slide runners under the drawers and certified electrical fittings.

Sicherheit und Dauer

Die Struktur wird von dem Markenzeichen Idropan garantiert, ein wasserabweisendes und Feuchtigkeit widerstehendes Spezialmelamin, das Qualitätsmöbel kennzeichnet. Das Unternehmen hat sich außerdem dem Konsortium des ökologischen Paneels angeschlossen und verwendet daher nur Paneele, die aus 100% aus Recyclingmaterial hergestellt wurden. Alle Elemente sind darauf ausgerichtet, das Bad in kompletter Sicherheit jeden Tag zu benutzen: patentierte Scharniere, Wandbefestigungen und Ausführungen, die auf die Einwirkung von Feuchtigkeit getestet sind, haltbare Räder für Rollwägen, versteckte Laufschienen unter den Schubladen, bescheinigte elektrische Zubehöre.

Sécurité et durée

Les caissons sont garantis par la marque Idropan, un panneau mélaminé hydrofuge spécial, résistant à l'eau et à l'humidité, qui caractérise les meubles de qualité. La société a aussi adhéré au consortium du panneau écologique et utilise seulement des panneaux fabriqués avec du matériel recyclé au 100%. Tous les éléments sont étudiés pour vivre la salle de bain en toute sûreté tous les jours. Charnières brevetées, accroches et finitions testées contre l'humidité, roues pour chariots résistants, glissières pas visibles pour les tiroirs, accessoires électriques certifiées.

Seguridad y duración

Los costados son garantizados por medio de la marca Idropan, un especial melaminado idrorepelente resistente al agua y a la humedad que va a marcar la alma escondida de todos los muebles de calidad. La empresa además está asociada al consorcio tablero ecológico y utiliza solo tableros efectuados con materiales reciclados por el 100%. Artesi estudio todos los elementos para vivir el ambiente baño cada día con toda seguridad: bisagras patentadas, enganches y acabados frentes que contrastan la acción de la humedad, ruedas de los contenedores, guías bajos cajones ocultas, componentes eléctricos certificados.



Materiale idrofugo di qualità resistente all'acqua ed all'umidità.

Waterproof material resistant to water and dampness.

Wasserabweisendes hochwertiges Material, das Wasser und Feuchtigkeit widersteht.

Matériel hydrofuge de haute qualité, résistant à l'eau et à l'humidité.

Material hidrófugo de calidad resistente al agua y a la humedad.



Pannello ecologico garantito 100% Legno riciclato.

Ecological panel made of 100% Recycled wood.

Ökologisches paneel, 100% aus Recyclingmaterial hergestellt.

Panneau écologique fabriqué en bois recyclé au 100%.

Tablero ecológico garantizado por el 100% de Maderas recicladas.



Marchio europeo di qualità Per i componenti elettrici.

European quality label for electrical components.

Europäisches Qualitätsmarkenzeichen für elektrische Komponenten.

Label de qualité européen pour les composants électriques.

Marca Europea de calidad por los componentes eléctricos.



Artesi ha un proprio Sistema di Gestione della Qualità, certificato dall'ente ICILA, secondo la norma UNI EN ISO 9001:2015. Tale certificazione ha lo scopo di gestire al meglio ogni processo aziendale. Il sistema qualità Artesi, attraverso un'accurata progettazione, selezione e controllo dei fornitori e dei processi produttivi, persegue il principale obiettivo della piena soddisfazione dei propri clienti.

Artesi has an own Quality Management System certified by ICILA according to the UNI EN ISO 9001:2015 regulation. This certification aims at conducting every company process in the best way. The quality system of Artesi hits the main target of the customer's full satisfaction by a careful planning, selection and control of the suppliers and the production procedures.

Artesi verfügt über ein eigenes, seitens der ICILA bescheinigtes Qualitätssystem gemäß UNI EN ISO 9001:2015-Norm. Dieses Zertifikat ist darauf ausgerichtet, jeden Betriebsvorgang in der bestmöglichen Weise zu führen. Das Qualitätssystem der Firma Artesi verfolgt hauptsächlich das Ziel, die eigenen Kunden mittels einer sorgfältigen Planung, Auswahl und Kontrolle der Lieferanten und der Produktionsverfahren voll zufriedenzustellen.

Artesi dispose d'un propre système de gestion de la qualité certifié ICILA selon la norme UNI EN ISO 9001:2015. Cette certification a le but de gérer au mieux chaque procédé de l'entreprise. Le système de qualité Artesi poursuit l'objectif principal de la pleine satisfaction du client par un projet soigneux, la sélection et le contrôle des fournisseurs et des procédés de production.

Artesi posee un sistema de gestión calidad, certificado por el ente ICILA, según la norma UNI EN ISO 9001:2015. Esa certificación tiene el fin de administrar en el mejor modo posible cada proceso de la empresa. El sistema de calidad Artesi, por medio de un cuidadoso planeamiento, selección y control de los proveedores y de los procesos productivos, persegue como principal objetivo la plena satisfacción de sus clientes.

AD
Progetto grafico
Rendering
styling
Fotolito
Stampa

Enrico Cesana
CO3 Design Studio
Nudesignstudio
Massimiliano Di Domenico
LuceGroup
Sinchromia 191362
Settembre 2019

ARTESI

Via Antonio Carpenè, 4
33070 Maron di Brugnera (PN)
T 0434 735353 **F** 0434 735373
E info@artesi.it

www.artesi.it